

**PATRICK & HENRY COMMUNITY COLLEGE
LOCAL FUNDS SUMMARY
Period Ending February 29, 2024**

<u>FUND BALANCES</u>	<u>BEG. BAL.</u>	<u>NET INCOME</u>	<u>END. BAL.</u>
LOCALITY FUNDS	\$222,445.74	\$88,104.03	\$310,549.77
AUXILIARY FUNDS ¹	\$972,487.46	\$62,569.42	\$1,035,056.88
STUDENT ACTIVITY FUNDS	\$50,841.79	(\$44,857.60)	\$5,984.19
PARKING FUNDS	<u>\$254,529.59</u>	<u>\$22,031.92</u>	<u>\$276,561.51</u>
TOTAL LOCAL FUNDS	\$1,500,304.58	\$127,847.77	\$1,628,152.35

¹Including Investment Gain/Loss

PATRICK & HENRY COMMUNITY COLLEGE
LOCALITY FUND BUDGET
Period Ending February 29, 2024

REVENUES		BUDGET	ACTUAL	VARIANCE
401020	Henry County	\$62,414.00	\$62,414.00	\$0.00
401040	Martinsville	\$19,835.00	\$19,835.00	\$0.00
401030	Patrick County	\$10,000.00	\$7,500.00	\$2,500.00
	<u>Bank Interest</u>	<u>\$200.00</u>	<u>\$65.78</u>	<u>\$134.22</u>
TOTAL REVENUES		\$92,449.00	\$89,814.78	\$2,634.22

EXPENSES		BUDGET	ACTUAL	VARIANCE
460040	61257 Physical Plant Repair & Maintenance	\$10,000.00		\$10,000.00
460010	68800 Contingency Expenses	\$7,500.00		\$7,500.00
460060	61246 Bank Charges	\$2,000.00	\$1,710.75	\$289.25
470010	62320 <u>Plant & Improvements-Construction</u>	<u>\$50,000.00</u>		<u>\$50,000.00</u>
TOTAL EXPENSES		\$69,500.00	\$1,710.75	\$67,789.25
NET INCOME		\$22,949.00	\$88,104.03	(\$65,155.03)

LOCALITY FUND BALANCE

<u>BEGINNING</u> <u>BALANCE</u>	<u>NET</u> <u>INCOME</u>	<u>ENDING</u> <u>BALANCE</u>
\$222,445.74	\$88,104.03	\$310,549.77

PATRICK & HENRY COMMUNITY COLLEGE
AUXILIARY FUND BUDGET
Period Ending February 29, 2024

REVENUES			BUDGET	ACTUAL	VARIANCE
406500	40751	College Bookstore	\$30,000.00	\$21,101.80	\$8,898.20
406510	40751	Vending	\$10,000.00	\$10,421.15	(\$421.15)
		Auxiliary Fees	\$21,000.00	\$21,000.00	\$0.00
<u>406530</u>	<u>40751</u>	<u>Miscellaneous</u>	<u>\$500.00</u>	<u>\$11.25</u>	<u>\$488.75</u>
TOTAL REVENUES			\$61,500.00	\$52,534.20	\$8,965.80

EXPENSES			BUDGET	ACTUAL	VARIANCE
		Transfer to Student Activities	\$35,000.00	\$35,000.00	\$0.00
465020		President's Office/Community Relations	\$5,000.00	\$3,422.57	\$1,577.43
465030		Administration Local Expenses	\$2,500.00	\$415.99	\$2,084.01
465040		Local Board Expenses	\$3,500.00	\$1,730.00	\$1,770.00
<u>465050</u>		<u>Contingency</u>	<u>\$5,000.00</u>		<u>\$5,000.00</u>
TOTAL EXPENSES			\$51,000.00	\$40,568.56	\$10,431.44

NET INCOME			\$10,500.00	\$11,965.64	
-------------------	--	--	--------------------	--------------------	--

AUXILIARY FUND BALANCE

<u>BEGINNING</u> <u>BALANCE</u>	<u>INVEST.</u> <u>GAIN/LOSS</u>	<u>NET</u> <u>INCOME</u>	<u>ENDING</u> <u>BALANCE</u>
\$972,487.46	\$50,603.78	\$11,965.64	\$1,035,056.88

**PATRICK & HENRY COMMUNITY COLLEGE
AUXILIARY FUNDS INVESTMENT PERFORMANCE
February 29, 2024**

	<u>Amount</u>
BEGINNING VALUE	\$867,067.24
Plus cash deposits	\$0.00
<u>Less cash withdrawals</u>	<u>\$0.00</u>
ADJUSTED BASIS	\$867,067.24

		<u>Month</u>	<u>FYTD</u>	<u>Cum.</u>	
		<u>Return</u>	<u>Return</u>	<u>Return</u>	
PORTFOLIO VALUE AS OF	7/31/2023	\$883,480.56	1.89%	1.89%	47.25%
	8/31/2023	\$867,977.96	-1.79%	0.11%	44.66%
	9/30/2023	\$844,242.07	-2.74%	-2.63%	40.71%
	10/31/2023	\$830,230.98	-1.62%	-4.25%	38.37%
	11/30/2023	\$871,763.72	4.79%	0.54%	45.29%
	12/31/2023	\$911,700.93	4.61%	5.15%	51.95%
	1/31/2024	\$908,719.12	-0.34%	4.80%	51.45%
	2/29/2024	\$917,671.02	1.03%	5.84%	52.95%

Gain/Loss **\$50,603.78**

**PATRICK & HENRY COMMUNITY COLLEGE
STUDENT ACTIVITIES BUDGET
Period Ending February 29, 2024**

REVENUES		BUDGET	ACTUAL	VARIANCE
100850	Student Activity Fees	\$115,000.00	\$81,710.79	\$33,289.21
	From Foundation	\$88,000.00	\$87,413.83	\$586.17
	From Auxiliary Funds	\$35,000.00	\$35,000.00	\$0.00
	<u>Club Receipts</u>	<u>\$2,000.00</u>	<u>\$1,025.00</u>	<u>\$975.00</u>
TOTAL REVENUES		\$240,000.00	\$205,149.62	\$34,850.38

EXPENSES		BUDGET	ACTUAL	VARIANCE
90101	Student Activities & Cultural Events (See Following Schedule)	\$240,000.00	\$250,007.22	(\$10,007.22)
TOTAL EXPENSES		\$240,000.00	\$250,007.22	(\$10,007.22)

NET INCOME		\$0.00	(\$44,857.60)	\$44,857.60
-------------------	--	---------------	----------------------	--------------------

STUDENT ACTIVITIES FUND BALANCE

<u>BEGINNING</u> <u>BALANCE</u>	<u>NET</u> <u>INCOME</u>	<u>ENDING</u> <u>BALANCE</u>
\$50,841.79	(\$44,857.60)	\$5,984.19

STUDENT ACTIVITIES FUNDS

BUDGET

PERIOD ENDING February 29, 2024

DEPT. CODE	ACTIVITY	BALANCE FORWARD 6/30/2023	TRANSFER FROM AUXILIARY	ANNUAL FOUNDATION SUPPORT	HEERF	FUNDRAISING & CLUB RECEIPTS	STUDENT ACTIVITIES FEE BUDGET	STUDENT ACTIVITIES FEES-ACTUAL	AVAILABLE FUNDS	CLUB EXPENSES	ENDING BALANCE
	BUDGETED REVENUES		\$35,000.00	\$88,000.00		\$2,000.00	\$115,000.00	\$81,710.79			
994010	INTERNATIONAL CLUB	\$605.12					\$500.00	\$355.26	\$960.38		\$960.38
994020	ALLIANCE FOR EXCELLENCE	\$2,833.79					\$600.00	\$426.32	\$3,260.10		\$3,260.10
994030	EARLY CHILDHOOD CLUB	\$1,386.23					\$500.00	\$355.26	\$1,741.49		\$1,741.49
994060	CAMPUS LIFE	\$2,045.60					\$6,000.00	\$4,263.17	\$6,308.77	\$4,978.93	\$1,329.84
994070	PHI THETA KAPPA	\$3,839.56					\$1,000.00	\$710.53	\$4,550.09	\$252.47	\$4,297.62
994080	INTERCOLLEGIATE ATHLETICS	\$0.00	\$35,000.00	\$87,413.83		\$1,025.00	\$90,000.00	\$63,947.57	\$187,386.40	\$235,130.25	(\$47,743.85)
994090	INTRAMURALS	\$533.68					\$1,500.00	\$1,065.79	\$1,599.47	\$559.57	\$1,039.90
994100	STUDENT GOV ASSOC	\$9,517.36					\$2,150.00	\$1,527.64	\$11,045.00	\$1,591.26	\$9,453.74
994120	ENVIRONMENTAL CLUB	\$554.49					\$200.00	\$142.11	\$696.60		\$696.60
994130	STUDENT NURSES ASSOC	\$6,166.69					\$500.00	\$355.26	\$6,521.95		\$6,521.95
994140	CULINARY CLUB	\$0.00					\$0.00	\$0.00	\$0.00		\$0.00
994160	STUDENT SERVICES ADV	\$184.99					\$300.00	\$213.16	\$398.15	\$59.58	\$338.57
994180	PLAY DAY, FALL FEST	\$4,808.28					\$3,000.00	\$2,131.59	\$6,939.87	\$3,290.00	\$3,649.87
994200	BROWN BAG SEMINAR	\$1,191.69					\$750.00	\$532.90	\$1,724.59	\$86.40	\$1,638.19
994210	DISCRETIONARY SA FUND	\$6,152.97					\$3,000.00	\$2,131.59	\$8,284.56	\$4,058.76	\$4,225.80
994230	VETERANS CLUB	\$2,833.74					\$500.00	\$355.26	\$3,189.00		\$3,189.00
994250	CULTURAL EVENTS	\$3,440.40					\$3,000.00	\$2,131.59	\$5,571.98		\$5,571.98
994260	STUDENT AWARDS BANQUET	\$381.32					\$1,000.00	\$710.53	\$1,091.85		\$1,091.85
994360	ADMIN OF JUSTICE ASSOC	\$1,000.00					\$0.00	\$0.00	\$1,000.00		\$1,000.00
994390	SMA	\$3,365.90					\$500.00	\$355.26	\$3,721.16		\$3,721.16
BUDGET TOTALS		\$50,841.79	\$35,000.00	\$87,413.83	\$0.00	\$1,025.00	\$115,000.00	\$81,710.79	\$255,991.41	\$250,007.22	\$5,984.19

**PATRICK & HENRY COMMUNITY COLLEGE
PARKING FUNDS BUDGET
Period Ending February 29, 2024**

REVENUES	BUDGET	ACTUAL	VARIANCE
409010 Student Parking Fees	<u>\$50,000.00</u>	<u>\$37,575.02</u>	<u>\$12,424.98</u>
TOTAL REVENUES	\$50,000.00	\$37,575.02	\$12,424.98

EXPENSES	BUDGET	ACTUAL	VARIANCE
490000 Site Improvements/Parking	<u>\$25,000.00</u>	<u>\$15,543.10</u>	<u>\$9,456.90</u>
TOTAL EXPENSES	\$25,000.00	\$15,543.10	\$9,456.90

NET INCOME	\$25,000.00	\$22,031.92	
-------------------	--------------------	--------------------	--

PARKING FUND BALANCE		
<u>BEGINNING BALANCE</u>	<u>NET INCOME</u>	<u>ENDING BALANCE</u>
\$254,529.59	\$22,031.92	\$276,561.51

PATRICK & HENRY COMMUNITY COLLEGE
Office of the President

Board Report #443
March 18, 2024

**BOARD TO CONSIDER APPROVAL OF
ACADEMIC PROGRAM CHANGES**

Report:

Certificate Closures within Industrial Electronics Technology

The field of Advanced Manufacturing is cutting edge. Specifically, technology and automation innovate routinely. P&HCC embraces the pace of the future and works to maintain relevant and impending methods, technologies, and other advancements within Advanced Manufacturing. In recent years, two Career Studies Certificates in Mechatronics and Robotics & Automation Technology exemplify the actions P&HCC undertakes to ensure employers receive the most dynamic and current graduates.

As a result, certificates that were viable merely a few years ago have become antiquated and do not serve the needs of employers as well as the current offerings. Keeping misaligned credentials open promotes confusion to students and advisors and neither optimizes potential student earnings nor aligns with employer needs. To that end, P&HCC is recommending the following closures:

Industrial Controls Career Studies Certificate

Industrial Maintenance Career Studies Certificate

It is important to note that these recommended closures are being replaced by more relevant credentials. This poses no negative impact to students as the current credentials in Mechatronics and Robotics & Automation align much better with employer need and enhances the student opportunity for higher wages.

Certificate Closure within General Studies: Visual Arts Specialization

As part of the annual program reviews, all credentials are reviewed to determine viability. Within the General Studies degree, there is currently a specialization of Visual Arts. This subset of ART courses has its own credential, the Art Studies Career Studies Certificate. In recent years, and rightfully so, policy and process have been put in place to evaluate all credentials on transferability and/or employability. The Art Studies Career Studies Certificate neither enhances transferability nor employability as it is not a standalone associate degree and it does not lead to viable wages. It is the recommendation from P&HCC to close the Art Studies Career Studies Certificate.

In all, three recommendations from the P&HCC Curriculum Committee for the 2025-26 academic year are:

- 1) Closure of the Industrial Controls CSC
- 2) Closure of the Industrial Maintenance CSC
- 3) Closure of the Art Studies CSC

Recommendation:

It is the recommendation of the college administration that the Board approve these Academic Program Changes.

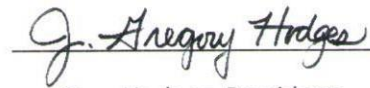
A handwritten signature in cursive script that reads "Greg Hodges". The signature is written in black ink and is positioned above a horizontal line.

Greg Hodges, President

PATRICK & HENRY COMMUNITY COLLEGE
Office of the President

Board Report #444
March 18,2024

**BOARD TO CONSIDER APPROVAL OF
LEASE/PURCHASE OF PASSENGER BUS**

Report:

The college is submitting to the board for approval its recommended lease/purchase of a new, 25-passenger bus.

P&HCC is seeking to replace the 29-passenger, 2007 Chevy bus. The 2007 Chevy has approximately 237,464 miles on the engine and is currently not running. The Chevy has extensive transmission issues, a roof leak, and minor electrical issues.

The college issued a Request for Proposals for a lease/purchase of a 25-passenger van to replace the existing Chevy van. The successful proposal was submitted by Sonny Merryman and is attached. It provides for a purchase price of \$130,282.80 and a five-year lease with monthly payments of \$2,171.38. The college has the option to purchase the van for \$1.00 at the conclusion of the lease. The college believes that the lease/purchase terms are reasonable and that the purchase of the vehicle is in the best interest of the college and for the safety of its students.

Recommendation:

It is the recommendation of the college administration that the Board approve the lease/purchase of a 25-passenger bus on the terms stated above.

Greg Hodges, President

EXHIBIT C OBLIGOR RESOLUTION

RE: Government Obligation Contract dated as of February 26, 2024, between KS StateBank (Obligee) and Patrick & Henry Community College, a Component Unit of Virginia Community College System (Obligor)

At a duly called meeting of the College Board of the Obligor (as defined in the Contract) held on _____
the following resolution was introduced and adopted:

BE IT RESOLVED by the College Board of Obligor as follows:

1. **Determination of Need.** The College Board of Obligor has determined that a true and very real need exists for the acquisition of the Equipment described on Exhibit A of the Government Obligation Contract dated as of February 26, 2024, between Patrick & Henry Community College, a Component Unit of Virginia Community College System (Obligor) and KS StateBank (Obligee).
2. **Approval and Authorization.** The College Board of Obligor has determined that the Contract, substantially in the form presented to this meeting, is in the best interests of the Obligor for the acquisition of such Equipment, and the College Board hereby approves the entering into of the Contract by the Obligor and hereby designates and authorizes the following person(s) to execute and deliver the Contract on Obligor’s behalf with such changes thereto as such person(s) deem(s) appropriate, and any related documents, including any Escrow Agreement, necessary to the consummation of the transaction contemplated by the Contract.

Authorized Individual(s):

(Typed or Printed Name and Title of individual(s) authorized to execute the Contract)

3. **Adoption of Resolution.** The signatures below from the designated individuals from the College Board of the Obligor evidence the adoption by the College Board of this Resolution.

Signature:

(Signature of Board Chairman or other authorized member of the Obligor's College Board)

Printed Name & Title:

(Printed Name and Title of individual who signed directly above)

Attested By:

(Signature of Obligor's Board Secretary or Board Clerk)

Printed Name & Title:

(Printed Name of individual who signed directly above)



December 16, 2023

Patrick Henry Community College
645 Patriot Avenue
Martinsville, VA 24112

Dear Tiffany:

Thank you for the opportunity to submit this bid in response to your request for RFP 44893-0 . We are offering a 2023 or newer Starcraft Allstar MVP on a Ford E-450 Chassis.

Should we receive an award for this solicitation, we will provide the material as outlined. The Starcraft Allstar MVP will be constructed in Goshen, Indiana.

I have attached a floor plan of the bus. Please note that delivery is estimated to be 8 - 10 months from ARO.

Thank you again for this opportunity. Please call if you have questions.

Sincerely,

Trey Myers
Commercial Bus Sales
804-514-9289
trey@sonnymerryman.com



Sonny Merryman Inc. has 4 service locations across the state (locations listed below).

- Evington, Va - 5120 Wards Road Evington Va 24550
- Chesapeake, VA - 1221 Fleetway Drive Chesapeake VA 23323
- Bristow, VA - 10149 Piper Lane Bristow VA 20136
- Richmond, VA - 11228 Hopson Road Ashland VA 23005

For Maintenance/Service, please contact Sonny Merryman Inc. Headquarters at 434-821-1000. Please contact the employee below for scheduled maintenance updates on the bus.

- Brady Childress
brady@sonnymerryman.com
434-485-8620

A loaner bus shall be provided if repairs are forecast to take longer than 14 consecutive days. If that is the case Sonny Merryman Inc. will drop off a loaner bus and pick up the bus needing repairs (if driveable).

Warranty Information:

- 12 month bumper to bumper warranty
- 5 year/100,000 mile starcraft body warranty
- 5 year/150,000 mile engine and powertrain (extended warranty)



Request for Proposals

Issue Date: November 29, 2023

RFP Number: VCCS-P&HCC-24-44893

Title: Lease Bus

Commodity Code: 97516- Automotive Accessories Rental or Lease (For Automobiles, Buses, Trucks, Vans, etc.)

Issuing Agency: Commonwealth of Virginia
Virginia Community College System
Shared Services Center
147 Daleville Centre Drive
Daleville, Virginia 24083

Contract Term: 60 month lease.

Proposals will be Received Until: **December 18, 2023, at 2:30 PM local time.**

All Proposals must be received in eVA’s Virginia Business Opportunities by the date and time stated immediately above. Any Proposals received after the stated time and date will not be considered.

In lieu of a Pre-Proposal Conference, questions will be accepted by email to Tiffany Ollie through **December 8, 2023, by 12 noon.** Any inquiries regarding this solicitation should be directed only to: **Tiffany Ollie, Strategic Sourcing Supervisor.** Email: tollie@ssc.vccs.edu Phone: (540) 591-4042

All inquiries must be made in writing and must be submitted electronically as indicated in the RFP. No oral inquiries will be accepted. From the date of issuance of this RFP, until the selection of a Contractor(s) is announced, all questions concerning any part of this RFP shall be directed ONLY to Tiffany Ollie (tollie@ssc.vccs.edu). It is not permissible for an Offeror, or any entity working on behalf of an Offeror, to solicit information from any individual or government source (Federal or State) other than from the official point of contact listed above. Any unauthorized solicitations for information are grounds for disqualification of Offeror’s proposal.

In compliance with this Request for Proposals (RFP) and to all the conditions imposed therein and hereby incorporated by reference, the undersigned offers and agrees to furnish the goods and services in accordance with the attached submitted proposal or as mutually agreed upon by subsequent negotiation.

Name of Firm: Sonny Merryman Inc.	Date: 12/16/2023
Address of Firm: 5120 Wards Road Evington, Va 24550	By: Trey Myers
eVA Vendor ID Number: C12391	Name: Trey Myers
DSBSD Certification Number: 9485	Title: Commercial Sales Representative
Phone: 804-514-9289	Email: trey@sonnymerryman.com

Note: This public body does not discriminate against faith-based organizations in accordance with the Code of Virginia, § 2.2-4343.1 or against a Contractor or offeror because of race, religion, color, sex, national origin, age, disability, sexual orientation, gender identity, political affiliation, or veteran status or any other basis prohibited by state law relating to discrimination in employment. Faith-based organizations may request that the issuing agency not include subparagraph 1.e in General Terms and Condition C. Such a request shall be in writing and explain why an exception should be made in that request for proposal.

ATTACHMENT 1 – VENDOR DATA SHEET

This form must be returned with your proposal

Note: The following information is required as part of your response to this solicitation.

Qualification: The vendor must have the capability and capacity in all respects to satisfy fully all of the contractual requirements.

Vendor's Primary Contact:

Name:	Trey Myers	Phone:	804-514-9289	Email:	trey@sonnymerryman.com
-------	------------	--------	--------------	--------	------------------------

Years in Business: Indicate the length of time you have been in business providing this type of good or service:

Years:	56	Months:	
--------	----	---------	--

Vendor Identification:

eVA Vendor ID:	C12391	DUNS Number:	01-005-3718
----------------	--------	--------------	-------------

References: Indicate below five (5) references for whom you have performed similar services.

Reference #1			
Company:	Metropolitan Washington Council of Governments	Contact Name:	Dan Sheehan
Phone:	(202)-962-3287	Email:	dsheehan@mwkog.org
Project:	Body on Chassis & Minivans	Project \$ Value:	\$1,300,000.00
Dates of Service:	2016 - Present	Notes:	

Reference #2			
Company:	Virginia Department of Rail and Public Transportation	Contact Name:	Avery Daugherty
Phone:	(804)-786-6796	Email:	avery.daugherty@drpt.virginia.gov
Project:	Paratransit Vehicles	Project \$ Value:	\$100,000,000.00
Dates of Service:	1992 - Present	Notes:	

Reference #3			
Company:	U.S. General Services Administration (GSA)	Contact Name:	Craig Yokum
Phone:	(703)-605-9291	Email:	craig.yokum@gsa.gov
Project:	Light/Medium Duty Shuttle Buses	Project \$ Value:	\$8,000,000.00
Dates of Service:	2014 - Present	Notes:	

Reference #4			
Company:	Maryland Department of Transportation	Contact Name:	Jason Keppel
Phone:	410-767-7330	Email:	jkeppel@mta.maryland.gov
Project:	Paratransit Vehicles	Project \$ Value:	
Dates of Service:		Notes:	

Reference #5			
Company:	Anne Arundel County	Contact Name:	Sam Snead
Phone:	410-222-7440	Email:	
Project:	Paratransit Vehicles	Project \$ Value:	
Dates of Service:		Notes:	

I certify the accuracy of this information.

Signed: Trey Myers Date: 12/16/2023

Name: Trey Myers Title: Commercial Sales Representative

ATTACHMENT 2 – STATE CORPORATION COMMISSION FORM

This form must be returned with your proposal

Virginia State Corporation Commission (“SCC”) registration information: The undersigned Offeror:

is a corporation or other business entity with the following SCC identification number: 01109164

-OR-

“ is not a corporation, limited liability company, limited partnership, registered limited liability partnership, or business trust

-OR-

“ is an out-of-state business entity that does not regularly and continuously maintain as part of its ordinary and customary business any employees, agents, offices, facilities, or inventories in Virginia (not counting any employees or agents in Virginia who merely solicit orders that require acceptance outside Virginia before they become contracts, and not counting any incidental presence of the offeror in Virginia that is needed in order to assemble, maintain, and repair goods in accordance with the contracts by which such goods were sold and shipped into Virginia from offeror’s out-of-state location)

-OR-

“ is an out-of-state business entity that is including with this proposal an opinion of legal counsel which accurately and completely discloses the undersigned offeror’s current contacts with Virginia and describes why those contacts do not constitute the transaction of business in Virginia within the meaning of § 13.1-757 or other similar provisions in Titles 13.1 or 50 of the Code of Virginia.

****NOTE**** >> Check the following box if you have not completed any of the foregoing options but currently have pending before the SCC an application for authority to transact business in the Commonwealth of Virginia and wish to be considered for a waiver to allow you to submit the SCC identification number after the due date for proposals (the Commonwealth reserves the right to determine in its sole discretion whether to allow such waiver): “

Signature: Trey Myers Date: 12/16/2023

Printed Name: Trey Myers

Title: Commercial Sales Representative

Name of Firm: Sonny Merryman Inc.

3/23/11

ATTACHMENT 3– PROPRIETARY AND CONFIDENTIAL INFORMATION FORM

This form must be returned with your proposal

Trade secrets or proprietary information submitted by an Offeror shall not be subject to public disclosure under the *Virginia Freedom of Information Act*; however, the Offeror must invoke the protections of § 2.2- 4342F of the *Code of Virginia*, in writing, either before or at the time the data or other material is submitted. The written notice must specifically identify the data or materials to be protected including the section of the proposal in which it is contained and the page numbers, and state the reasons why protection is necessary. The proprietary or trade secret material submitted in the original and all copies of the proposal must be identified by some distinct method such as highlighting or underlining and must indicate only the specific words, figures, or paragraphs that constitute trade secret or proprietary information. In addition, a summary of proprietary information submitted shall be submitted on this form. The classification of an entire proposal document, line item prices, and/or total proposal prices as proprietary or trade secrets is not acceptable. If, after being given reasonable time, the Offeror refuses to withdraw such a classification designation, the proposal will be rejected.

Name of Offeror (Firm): _____ invokes the protections of § 2.2-4342F of the *Code of Virginia* for the following portions of my proposal submitted on _____ Date

Signature: _____

Title: _____

No portion of this proposal is to be considered confidential and/or proprietary.

DATA/MATERIAL TO BE PROTECTED	SECTION NO., & PAGE NO.	REASON WHY PROTECTION IS NECESSARY

ATTACHMENT 4 – SMALL BUSINESS SUBCONTRACTING PLAN

This form must be completed and returned with the proposal.

Small Business Subcontracting Plan

It is the goal of the Commonwealth that over 42% of its purchases be made from small businesses. All potential offerors are required to return this document with their response.

Small Business: "Small business (including micro)" means a business which holds a certification as such by the Virginia Department of Small Business and Supplier Diversity (DSBSD) on the due date for proposals. This shall also include DSBSD-certified women-owned and minority-owned businesses and businesses with DSBSD service disabled veteran owned status when they also hold a DSBSD certification as a small business on the proposal due date. Currently, DSBSD offers small business certification and micro business designation to firms that qualify.

Certification applications are available through DSBSD online at www.SBSD.virginia.gov (Customer Service).

Offeror Name: Sonny Merryman Inc.

Preparer Name: Trey Myers **Date:** 12/16/2023

Who will be doing the work: I plan to use subcontractors I plan to complete all work

Instructions

- A. If you are certified by the DSBSD as a micro/small business, complete only Section A of this form.
- B. If you are not a DSBSD-certified small business, complete Section B of this form. For the offeror to receive credit for the small business subcontracting plan evaluation criteria, the offeror shall identify the portions of the contract that will be subcontracted to DSBSD-certified small business for the initial contract period in Section B.

Offerors which are small businesses themselves will receive the maximum available points for the small business participation plan evaluation criterion, and do not have any further subcontracting requirements.

Offerors which are not certified small businesses will be assigned points based on proposed expenditures with DSBSD-certified small businesses for the initial contract period in relation to the offeror's total price for the initial contract period.

Points will be assigned based on each offeror's proposed subcontracting expenditures with DSBSD-certified small businesses for the initial contract period as indicated in Section B in relation to the offeror's total price.

Section A

If your firm is certified by the DSBSD provide your certification number and the date of certification.

Certification number: 9485 Certification Date: 02/14/2020

Section B

If the "I plan to use subcontractors box is checked," populate the requested information below, per subcontractor to show your firm's plans for utilization of DSBSD-certified small businesses in the performance of this contract for the initial contract period in relation to the offeror's total price for the initial contract period. Certified small businesses include but are not limited to DSBSD-certified women-owned and minority-owned businesses and businesses with DSBSD service disabled veteran-owned status that have also received the DSBSD small business certification. Include plans to utilize small businesses as part of joint ventures, partnerships, subcontractors, suppliers, etc. It is important to note that these proposed participation will be incorporated into the subsequent contract and will be a requirement of the contract. Failure to obtain the proposed participation dollar value or percentages may result in breach of the contract.

C. Plans for Utilization of DSBSD-Certified Small Businesses for this Procurement

Subcontract #1

Company Name: _____ SBSB Cert #: _____
Contact Name: _____ SBSB Certification: _____ Contact
Phone: _____ Contact Email: _____
Value % or \$ (Initial Term): _____ Contact Address: _____
Description of Work: _____

Subcontract #2

Company Name: _____ SBSB Cert #: _____
Contact Name: _____ SBSB Certification: _____ Contact
Phone: _____ Contact Email: _____
Value % or \$ (Initial Term): _____ Contact Address: _____
Description of Work: _____

Subcontract #3

Company Name: _____ SBSB Cert #: _____
Contact Name: _____ SBSB Certification: _____ Contact
Phone: _____ Contact Email: _____
Value % or \$ (Initial Term): _____ Contact Address: _____
Description of Work: _____

Subcontract #4

Company Name: _____ SBSB Cert #: _____
Contact Name: _____ SBSB Certification: _____ Contact
Phone: _____ Contact Email: _____
Value % or \$ (Initial Term): _____ Contact Address: _____
Description of Work: _____

Subcontract #5

Company Name: _____ SBSB Cert #: _____
Contact Name: _____ SBSB Certification: _____ Contact
Phone: _____ Contact Email: _____
Value % or \$ (Initial Term): _____ Contact Address: _____
Description of Work: _____

ATTACHMENT 5 – PROHIBITION OF POLITICAL CONTRIBUTIONS & GIFTS

This form must be completed and returned with the proposal.

CERTIFICATION OF COMPLIANCE

WITH PROHIBITION OF POLITICAL CONTRIBUTIONS AND GIFTS DURING THE PROCUREMENT PROCESS

For contracts with a stated or expected value of \$5 million or more except those awarded as the result of competitive sealed bidding

I, Trey Myers, a representative of Sonny Merryman Inc.,
Please Print Name *Name of Offeror*

am submitting a bid/proposal to the Virginia Community College System in response to **RFP #XXX**, a solicitation where stated or expected contract value is \$5 million or more which is being solicited by a method of procurement other than competitive sealed bidding as defined in § 2.2-4301 of the *Code of Virginia*.

I hereby certify the following statements to be true with respect to the provisions of §2.2-4376.1 of the *Code of Virginia*. I further state that I have the authority to make the following representation on behalf of myself and the business entity:

1. The offeror shall not knowingly provide a contribution, gift, or other item with a value greater than \$50 or make an express or implied promise to make such a contribution or gift to the Governor, his political action committee, or the Governor's Secretaries, if the Secretary is responsible to the Governor for an agency with jurisdiction over the matters at issue, during the period between the submission of the proposal and the award of the contract.
2. No individual who is an officer or director of the offeror, shall knowingly provide a contribution, gift, or other item with a value greater than \$50 or make an express or implied promise to make such a contribution or gift to the Governor, his political action committee, or the Governor's Secretaries, if the Secretary is responsible to the Governor for an agency with jurisdiction over the matters at issue, during the period between the submission of the proposal and the award of the contract.
3. I understand that any person who violates § 2.2-4376.1 of the *Code of Virginia* shall be subject to a civil penalty of \$500 or up to two times the amount of the contribution or gift, whichever is greater.

Trey Myers
Signature

Commercial Sales Representative
Title

12/16/2023
Date

ATTACHMENT 6 – SPECIFICATIONS

This form must be returned with response to solicitation

Offeror shall complete this form and submit with proposal.

Below is a list of the goods to be purchased as a result of this RFP. Offerors are instructed to check each line item that your company can supply per specifications. If you have an equivalent do not check the box but list the equivalent on the appropriate line. Submit all equivalent documentation with proposal.

TRACTOR SPECIFICATIONS:

Description:	Lease Bus(es)		
Quantity:	One (1) or Two (2) Lease		
Description	Check line item if you can meet the specification	Equivalent	
Make: StarCraft Allstar MVP	✓		
Length: 27'	✓		
Wheelbase: 212"	✓		
Chassis: E450	✓		
Engine: 7.3L Gas	✓		
GVWR: 14,500 pounds	✓		
Passenger Capacity: 25	✓		
Overall Width: 96"	✓		
Overall height: 116"	✓		
Interior Width: 93"	✓		
Interior Height: 80"	✓		
Ground to Int. Floor: 30"	✓		
Ground to First Step: 12"	✓		
Step Riser: 9"	✓		
Step Thread: 11.5"	✓		
Step Width: 35.75"	✓		
Entry Door Clear with Opening with One Grab Rail: 31"	✓		
Entry Door Clear with Opening with Two Grab Rail: 30"	✓		
Standard Features:			
LED exterior Lighting Including: 5 Front Amber, 7 Rear Red, Red Stop/Tail, and Turn Signal, Backup Clear, Tag Light	✓		
Rosco Accustyle manual Exterior Breakaway Mirrors	✓		
One Piece Fiberglass Front Cap	✓		
One Piece Fiberglass Rear Cap With Anti-ride Feature and 30"X48" Nominal Rear Egress Window	✓		
Heavy Die-formed, Black Powder Coated, Steel Bumper	✓		
Grey Padded Vinyl Driver Overhead Panel, Electrical Cover Panel, Access Door, Entry Door and B Pillar Covering	✓		
Seaspray Fabric Covered Ceiling and Sidewalls	✓		
Vandal Resistant Frame Above Seat Track to the Transition Panel	✓		

Interior Led Lighting: Passenger Dome Lights (Qty Pending Length of Vehicle), Driver's Dome, Entry Stepwell Lights	✓	
5/8" Thick Plywood Over Floor Steel Structure	✓	
Graphite (Black) Gerflor Flooring With White Step Nosing	✓	
Left Hand Entry Vertical Stainless Steel Grab Rail. Stainless Steel Stanchion With Grey Padded Modesty Panel	✓	
36"X36" Upper T-slide Windows Tinted to FMVSS Compliance	✓	
36" Wide Clear Opening, Electric Entry Door (Front Lift 138"/139" WB Models Can Only Use 32" Wide Clear Opening Entry Door)	✓	
Rear Mud Flaps	✓	
COMFORT & CONVENIENCE UPGRADE OPTIONS		
Rear Luggage 20203	✓	

Estimated delivery date once a purchase order is issued: 8-10 months from date of PO

Name of Company: Sonny Merryman Inc.



Specifications:

ALLSTAR MVP 27 212" WB E-450 7.3L Premium Gas Engine W/240 Amp Ford Alt
SPECIAL BUILD OPTIONS
AS-BUILT PARTS MANUAL ON FLASH DRIVE
WARRANTY
12-MONTH / 12,000 MILE LIMITED COMMERCIAL WARRANTY W/ 5-YEAR / 100,000 MILE STRUCTURAL WARRANTY
ELECTRICAL SYSTEM
Intermotive Flex Tech Electrical System
SIDEWALL / REARWALL / CEILING
Sidewall: Grey FRP
Rearwall: Grey Seaspray Fabric
Ceiling: Grey Seaspray Fabric
Driver Area: Grey Padded Vinyl
FLOORING - WHITE NOSING IS STANDARD
Aisle: Gerflor Sirius NT #6801 Graphite (Black)
Under Seats: Gerflor Sirius NT #6801 Graphite (Black)
CHASSIS
Front Mud Flaps, pair - NOT AVAILABLE ON FORD TRANSIT
ENVIRONMENTAL CONTROL
TRANS/AIR AIR CONDITIONING SYSTEMS
DUAL COMPRESSOR SYSTEMS CEILING MOUNT EVAPORATOR
TA 733 SUPER 70K - TA73 EVAP - SMC3L COND - 10 C.I.D. COMP (SELECT CHASSIS/ENGINE BELOW)
TA733 SUPER 10 FORD 7.3 LITRE PREMIUM GAS ENGINE
HEATERS
Rear Hot Water Heater, 40K BTU 3 Speed
ELECTRICAL
Wiring Diagram "AS BUILT" ON USB Flash Drive
EXTERIOR LIGHTS
Surface Mount LED Entry Door Exterior Light - STD Choose Optional Below or Special builds
LED Rear Center Mount Brake Light, Rectangular
INTERIOR LIGHTS
Door Activated Interior Lights
AUDIO / VISUAL
FORD E-SERIES OEM AM/FM/BT RADIO ORDERED ON CHASSIS
4 Speakers with Wire to Chassis OEM Radio (if supplied)
DOORS / HATCH / WINDOWS
Electric Entry Door is Standard. Add Option #2056 if Manual is Desired
Passenger Door Electric (standard)
Passenger Door 36" ROUGH OPENING (STANDARD)
LUGGAGE RACK / STORAGE
Rear Luggage Area w/Rear Door,Felt Liner,Escape Hatch,Light,Rubber Floor
SAFETY OPTIONS
5 Lb Fire Extinguisher
16 Unit First Aid Kit
Body Fluid Kit
Emergency Triangle Kit
STANDARD ROSCO STSK4750 BACK-UP CAMERA SYSTEM W/ 7" REARVIEW MONITOR / MIRROR COMBO
GRAB RAIL / STANCHION / PANELS
Left Hand Entry Vertical Grab Rail - 1 1/4"
Stanchion and Modesty Panel at Entry Door
Padding on Stanchion - Gray - Per 40" Max Length Each (note location(s) below)
SEATING - DRIVER
SHIELD FC Recliner(GM&Ford), RH Arm, 4 Position Lumbar, Mesh Pocket
FREEDMAN SHIELD DRIVER SEAT FABRICS
Driver Seat Cover - Level 1 Newport Vinyl; Oxen Vinyl; Olefin
SEATING - PASSENGER
STD RIGID SEATS
Mid High Double Seat
Mid High Single Seat
PASSENGER SEAT FABRICS
Seat Cover - Level 1 Newport Vinyl; Oxen Vinyl; Olefin
SEAT BELTS
Seat Belt, Non-Retractable ****STANDARD ITEM - ENTER QUANTITY



To please our customers.
To serve our communities.
To drive people forward.

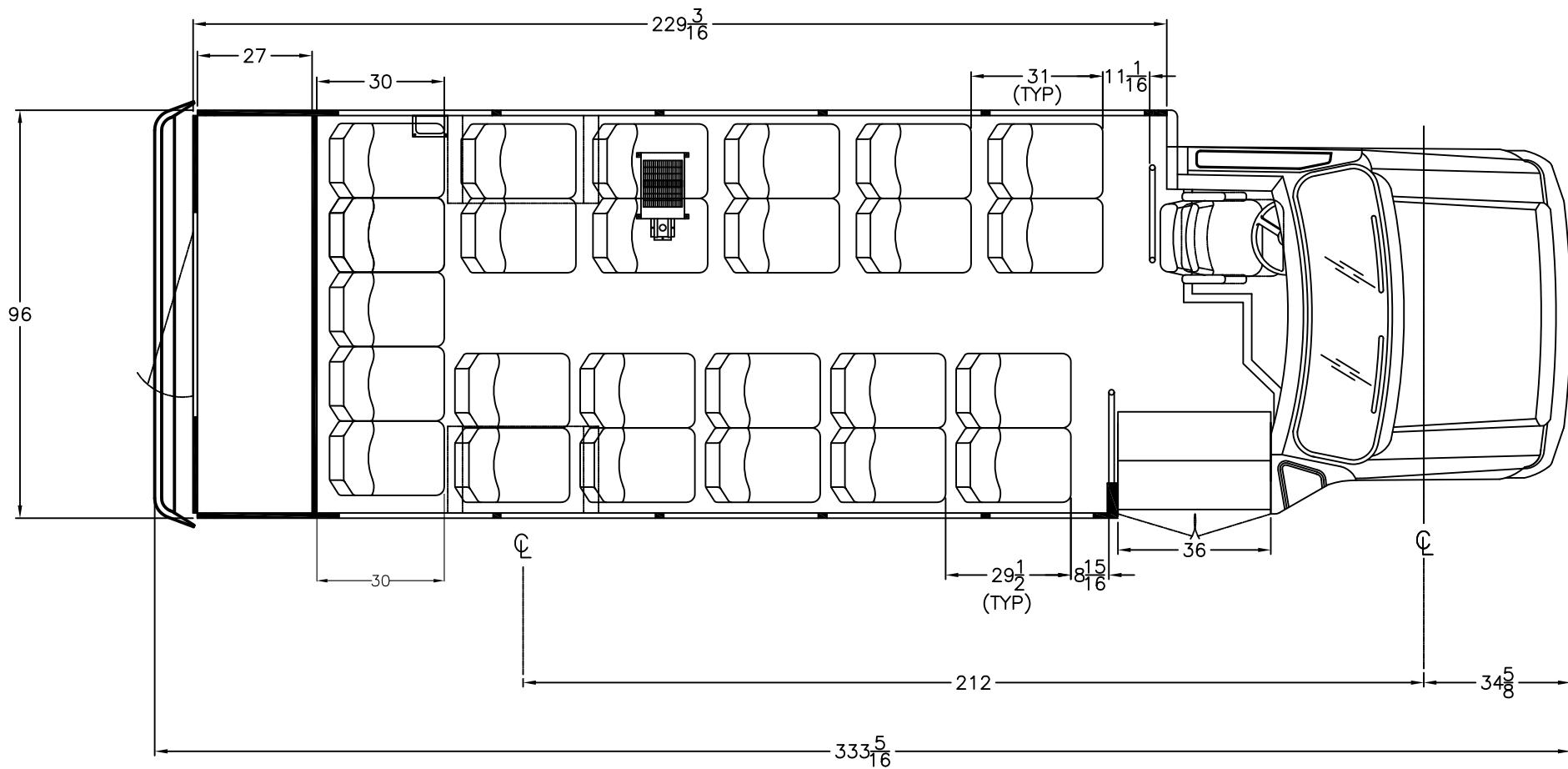

NOTE: SHOWN WITH MID HI FREEDMAN SEATS
 ALLSTAR E-450 14,500 GVWR
 THIS FLOOR PLAN IS FOR ILLUSTRATION PURPOSES ONLY.
 A WEIGHT ANALYSIS HAS NOT YET BEEN PERFORMED.
 FINAL APPROVAL WITH A WEIGHT ANALYSIS IS REQUIRED UPON RECEIPT
 OF A COMPLETED ORDER WITH ALL OPTIONS SHOWN.
 OPTIONAL EQUIPMENT MAY BE SHOWN.
 THE SALES ORDER PLACED DICTATES ACTUAL OPTION CONTENT.

DEALER APPROVAL

APPROVED

 CUSTOMER SIGNATURE

SCALE
 IN INCHES



THIS DRAWING AND THE INFORMATION THEREON ARE THE EXCLUSIVE PROPERTY OF STARCRAFT BUS, A DIVISION OF FOREST RIVER. IT SHALL NOT BE COPIED OR DUPLICATED IN ANY MANNER, NOR SHALL IT BE SUBMITTED TO OUTSIDE PARTIES FOR EXAMINATION WITHOUT OUR WRITTEN CONCENT. IT IS LOANED FOR USE WITH REFERENCE TO WORK UNDER CONTRACT WITH, OR PROPOSALS SUBMITTED TO STARCRAFT BUS, A DIVISION OF FOREST RIVER.

REV. LET.	DESCRIPTION OF CHANGE	BY	CHK	DATE	ECN No.

TOLERANCE UNLESS OTHERWISE SPECIFIED		STARCRAFT BUS a division of Forest River, Inc.	
WOOD	OTHER	DATE: 07/07/17	TITLE: 25 PASS. 27" REAR LUGGAGE 212" WB 27' ALLSTAR MVP
± 1/8"	± 1/16"	NAME: JPC	DWG. No.
± 1"	± 1/2"	25 PASS 27 R LUG 212 217 USA	

ATTACHMENT 7 – PRICING SCHEDULE

This form must be returned with response to solicitation

Offeror shall submit pricing in the format shown below, based on the terms and conditions set forth in this RFP to furnish all necessary labor, travel, supervision, tools, materials, testing and all other necessary appurtenances and work necessary to complete a turnkey project in accordance with the specification to deliver one (1) or two (2) lease bus(es) to P&HCC for five years (60 month) lease. It is at the discretion of the College to award a lease for one (1) or two (2) buses. The rate provided will be for any number of bus(es) leased as a product of this RFP.

PRICING:

Offeror shall enter a firm total cost for a five (5) years/(sixty (60) month) lease. At the end of the lease the College has the discretion to purchase the leased bus at a value of \$1.00. The leased bus shall allow up to 20,000 miles per each year to be included with the monthly cost. **Number 1 – 5 below needs to be filled out and returned with proposal.**

1.

DESCRIPTION	UNIT OF MEASURE	QUANTITY	UNIT Monthly Rate	EXTENDED Rate
Provide a Firm Monthly Rate for one bus for a five year/sixty (60) month lease	EACH	60 months	\$ 2,171.38	\$ 130,282.80

The quantity is estimates only and may be more or less at time of award

2. Provide a fixed interest rate (inclusive of ALL financing costs) for the term of the lease: 5.660%

3. Provide an interest rate: 5.660%

4. Interest rate index: Indexed 5 year UST + 175

*If the lease does not fund at the rate quoted within thirty days of award, the college requests that the rate be indexed a week before funding.

5. Overage rate per mile for miles over the 20,000 per each year: \$ 0

*The overage rate will not be considered in the evaluation of proposal.

Estimated delivery date once a purchase order is issued: 8 - 10 Month Lead Time From PO

Name of Company: Sonny Merryman Inc.



Baystone Government Finance

December 18, 2023

FORMAL PROPOSAL

OBLIGOR: VIRGINIA COMMUNITY COLLEGE SYSTEM - PATRICK & HENRY COMMUNITY COLLEGE

- ✓ This is a finance/ownership contract. No residual value.
- ✓ Fixed interest rate for the five (5) year term.

EQUIPMENT: (1) STARCRAFT ALLSTAR MVP

OPTION 1

Acquisition Cost:	\$108,595.00	Term:	Five (5) years	First Payment Due:	November 1, 2024
Down Payment:	\$ 0.00	Payment Mode:	Monthly	Payment Amount:	\$2,171.38
Trade In:	\$ 0.00	Interest Rate:	5.660%		
Principal Balance:	\$108,595.00	Rate Factor:	0.019995		

ESCROW STRUCTURE

- ✓ Escrow Funding Date: January 5, 2024
- ✓ **No Premature Disbursements from Escrow Allowed.**
- ✓ This rate expires on January 18, 2024.
- ✓ Escrow Agreement with KS StateBank.

- This is a proposal only and is not a commitment to finance. This proposal is subject to credit review and approval and proper execution of mutually acceptable documentation.
- Failure to consummate this transaction once credit approval is granted and the documents are drafted and delivered to Obligor may result in a documentation fee being assessed to the Obligor.
- This transaction must be credit approved, all documents properly executed and returned to Baystone Government Finance and the transaction funded on ALL proposals on or before January 18, 2024. If funding does not occur within that time-frame, or there is a change of circumstance which adversely affects the expectations, rights, or security of Obligee or its assignees, then Obligee or its assignees reserve the right to adjust and determine a new interest rate factor and payment amount, or withdraw this proposal in its entirety. Should there be a significant change in market rates at any time prior to funding of the transaction, Baystone Government Finance reserves the right to adjust the Interest Rate quoted above.
- This transaction must be designated as tax-exempt under Section 103 of the Internal Revenue Code of 1986 as amended.
- **OBLIGOR'S TOTAL AMOUNT OF TAX-EXEMPT DEBT TO BE ISSUED IN THIS CALENDAR YEAR WILL NOT EXCEED THE \$10,000,000 LIMIT, OR THE INTEREST RATE IS SUBJECT TO CHANGE.**

BAYSTONE GOVERNMENT FINANCE

David Burr ~ dburr@ksstate.bank
Assistant Vice President

**VIRGINIA COMMUNITY COLLEGE SYSTEM -
PATRICK & HENRY COMMUNITY COLLEGE**

Signature

Title

Date

1010 Westloop Place, Manhattan, KS 66502
800.752.3562 ~ Fax: 785.537.4806